

ÜBERSETZUNG DER PRODUKTANLEITUNG

Größe: L420 * B240 * H240 (cm)

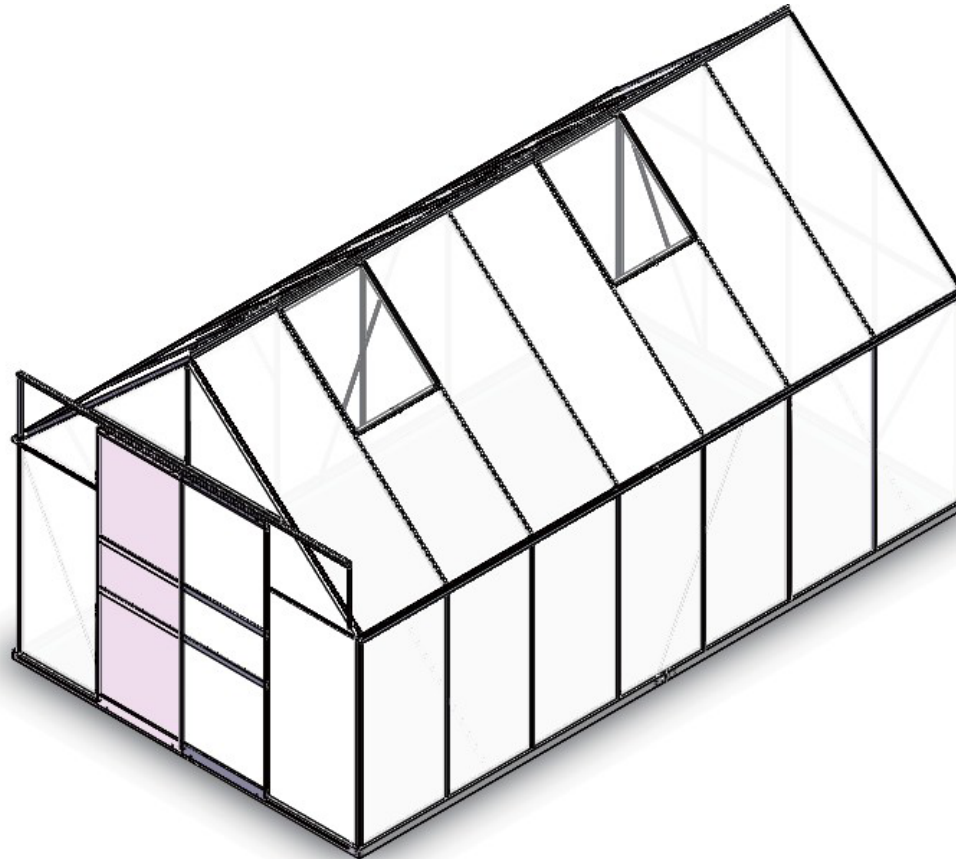

- Lesen Sie vor dem Zusammenbau die gesamte Bedienungsanleitung.
- Verwenden Sie die Teileliste, um sicherzustellen, dass Sie alle Teile erhalten haben
- Tragen Sie während der Montage eine geeignete Schutzbrille oder andere Schutzausrüstung

Vor der Montage

Bitte lesen Sie diese Anleitung vor der Installation sorgfältig durch. Lokale Sicherheitsvorschriften und Industriestandards müssen bei der Installation befolgt werden. Die Verordnungen können sich unter anderem auf Folgendes erstrecken:

- Schutzhelme, Augenschutz und Schutzkleidung
- Sicherheitsgurt für Arbeiter, die in der Höhe arbeiten
- Ordnungsgemäße Leiter, Käfig und deren sichere Verwendung

Prüfen Sie alle Komponenten und Teile vor dem Einbau. Alle Teile sind mit einer Nummer gekennzeichnet, vergleichen Sie diese Nummern bei der Prüfung mit der mitgelieferten Stückliste.

Wählen Sie für die Installation einen windstillen Tag oder einen Tag mit mäßigem Wind. Bei starkem Wind ist die Montage eine Herausforderung. Verändern Sie die Konstruktion in keiner Weise. Hängen Sie während der Montage keine Gewichte oder Teile an den Rahmen. Wir haften nicht für Schäden oder Verletzungen, die durch unsachgemäße Installation, nicht autorisierte Änderungen oder extreme Witterungseinflüsse entstehen. Dieser Bau ist nicht für Wohnzwecke vorgesehen.

Wir empfehlen, den Rahmen an der Stelle, an der sich die Fugen berühren und der Rahmen die Abdeckung berührt, zu kleben oder mit Schaumstoff/Gummi zu versehen. Dadurch wird die Lebensdauer des Gehäuses verlängert.

Lesen Sie sich vor dem Zusammenbau zunächst die Stückliste durch und zählen Sie die Artikel, damit Sie wissen, dass Sie alles vorbereitet haben.

Hauptspezifikationen

Gesamtgröße für die Montage (cm) :D 420 * B 240 * H 240 (cm)

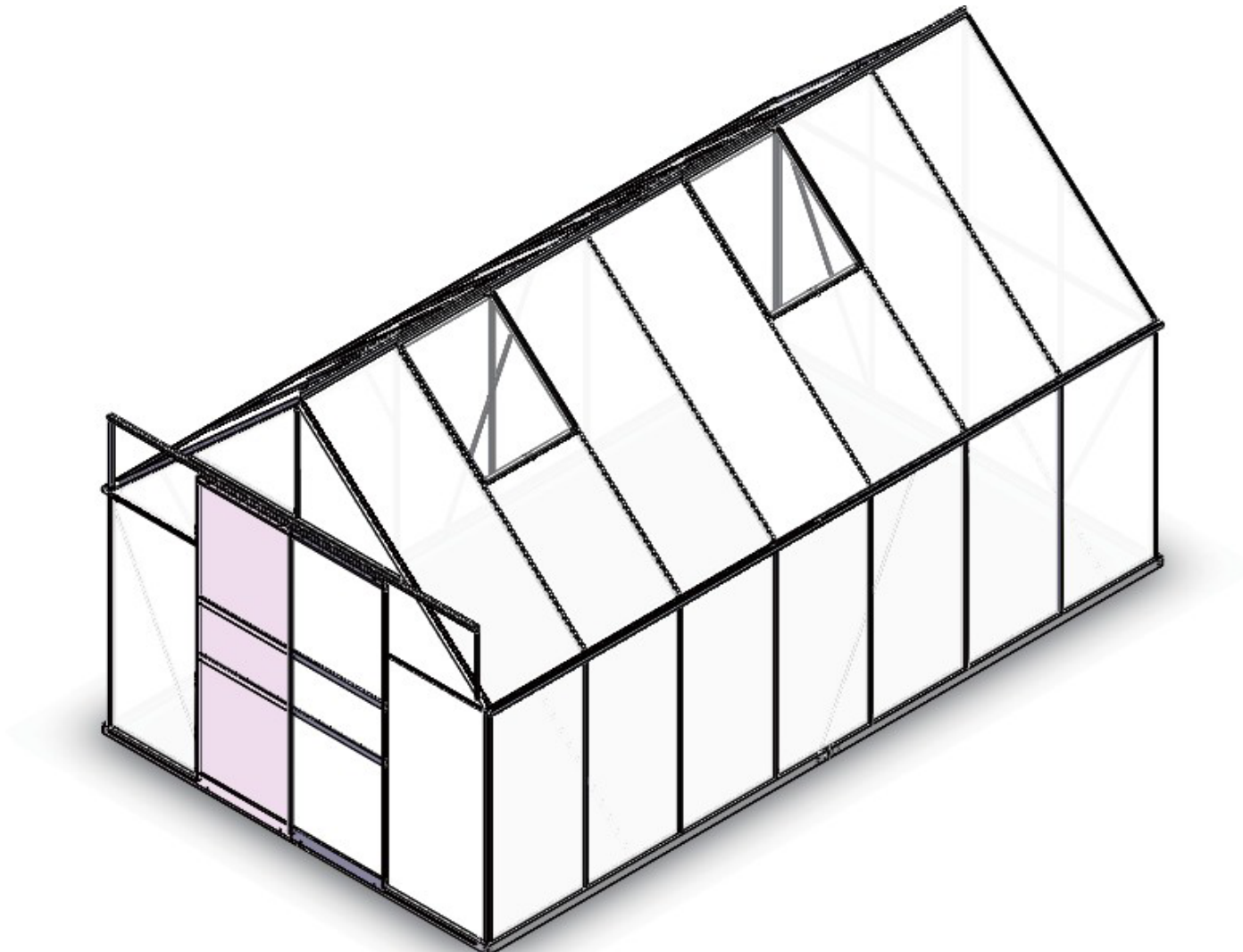

Empfohlene Werkzeuge

Schutzausrüstung:

1. Schutzhelm
2. Handschuhe
3. Schutzbrille



Messgeräte und Montagegeräte:

1. Maßband
2. Winkelmaß
3. Stehleiter
4. C10 Schraubenschlüssel
5. Kreuzschraubenzieher
6. Markierer
7. Hammer

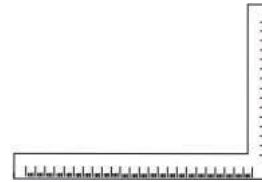
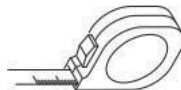



2. LISTE DER TEILE







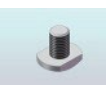

























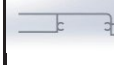





MODEL – MODELL

CODE – CODE

LENGTH – LÄNGE

QTY - MENGE

Model	Code	Length(mm)	QTY	Model	Code	Length(mm)	QTY	Model	Code	Length(mm)	QTY	Model	Code	Length(mm)	QTY
	3BJ1	L2099	2		2BJ12	L65*W12*H1.5	2		A1	M6X9*3.5	240		3PC6	L1564*W582*H6	10
	3BJ2	L2059	2		2BJ14	L100*W36.5*H11.5	2		A2	M6-GB41	245		3PC7	L850*W582*H6	4
	3BJ3	L1167	1		2BJ9	L100*W22*H11.5	3		C2	40	4		3PC3	L725*W567*H6	4
	3BJ4	L1207	1		2BJ10	L175*W23*H23	1		C3	332	4		3PC8	L1222*W576*H6	4
	3BJ5	L1167	1		2BJ8	L40*W30*H30	4		3PC4	L1222*W624*H6	2		3PC10	L540*W576*H6	2
	3BJ6	L1207	1		C1	L23	8		3PC1	L598.5*W568*H6	4		3PC12	L1061*W576*H6	2
	2BJ11	L144.3*W67.4*H1.5	4		D1	ST4.8X19	35		3PC2	L259.5*W568*H6	2		KH		210
	2BJ7	L150*W44*H12	4		D2	M4X10	10		3PC14	L453*W624*H6	2		3BJ7	574.31	4
	C4	L28	2		D3	ST4.2X9.5	20		3PC16	L668*W602*H6	2		D8		4
	2BJ15	L80*W65*H1.5	2		D4	M6X40-GB5780	3		3PC5	L1224*W582*H6	14				

Model	Code	Length(mm)	QTY	Model	Code	Length(mm)	QTY	Model	Code	Length(mm)	QTY	Model	Code	Length(mm)	QTY
	3A1	L581	1		3B2-4	L1575	1		3F1	L388	2		3M1	L560	2
	3A2	L1226	12		3C1	L1060	1		3G1	L605.5	4		3N1	L570	4
	3A3	L1553	12		3C2	L1203.6	1		3H1	L2117	2		3O1	L570	2
	3A4-1	L1765	1		3D1	L582	2		3H2	L2028	2		3P1-1	L1626	2
	3A4-2	L1765	1		3D2	L599	2		3I1	L2083	1		3P1-2	L1626	2
	3A5	L2260	1		3D3	L609.5	2		3I2	L2010	1		3Q1	L570	2
	3B1	L1226	4		3D4	L1320	2		3J1	L2260	1		3R1	L700	8
	3B2-1	L1575	1		3D5	L1362	6		3K1-1	L1681	1		3S1	L572	4
	3B2-2	L1575	1		3D6	L1306.5	2		3K1-2	L1681	1		3T1	L567	4
	3B2-3	L1575	1		3E1	L574	4		3L1	L1310	1				
					3E2	L622	2								

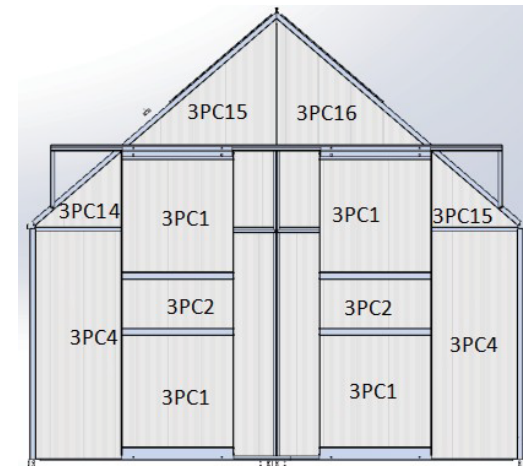
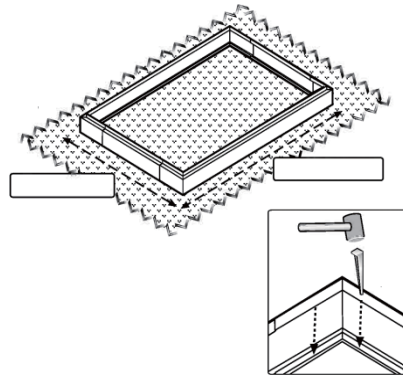
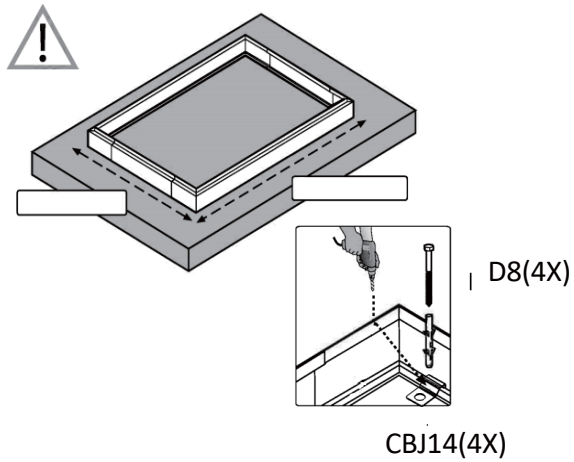
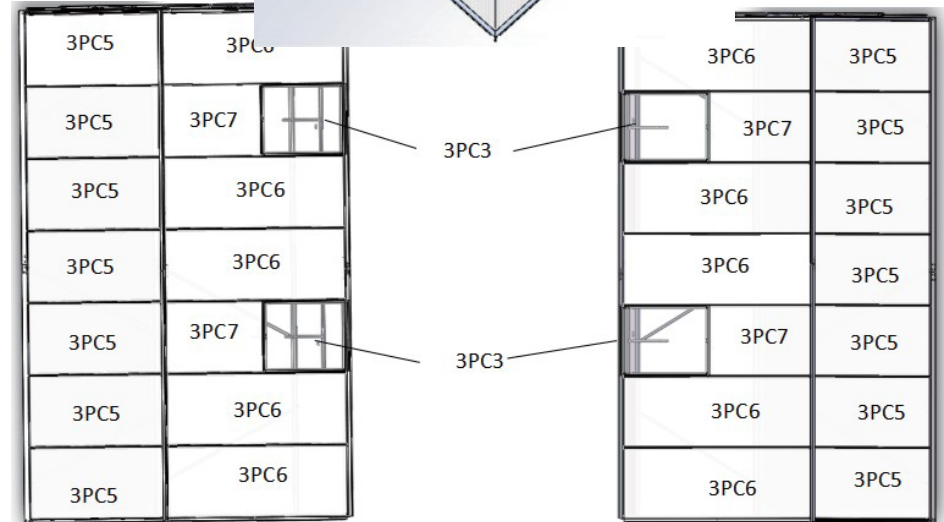
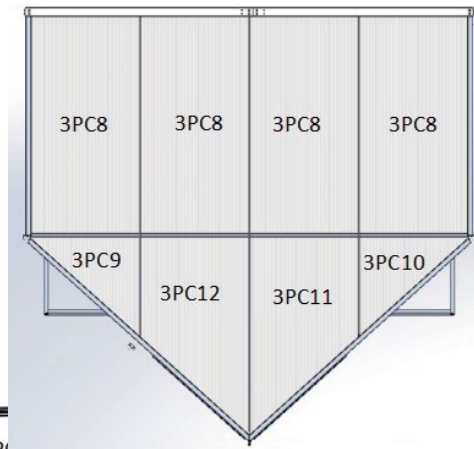
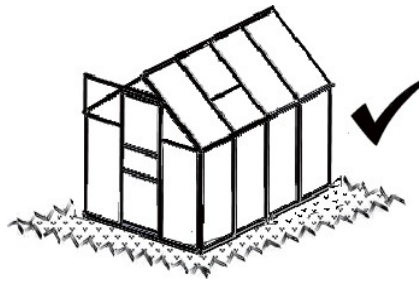
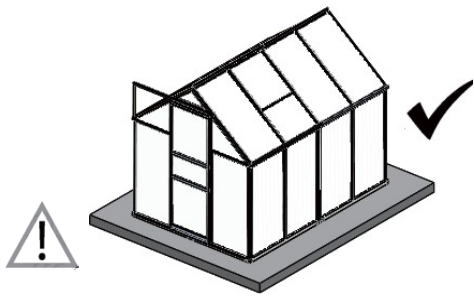

3. ANORDNUNG DER TEILE

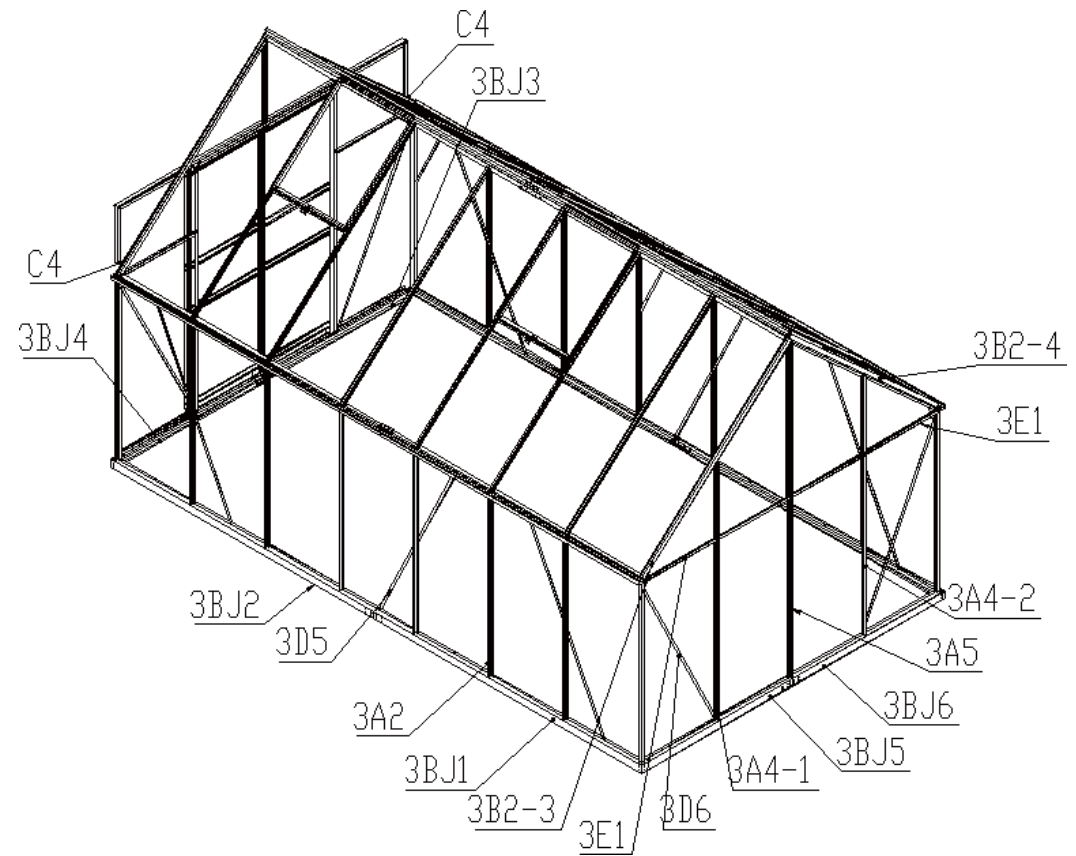
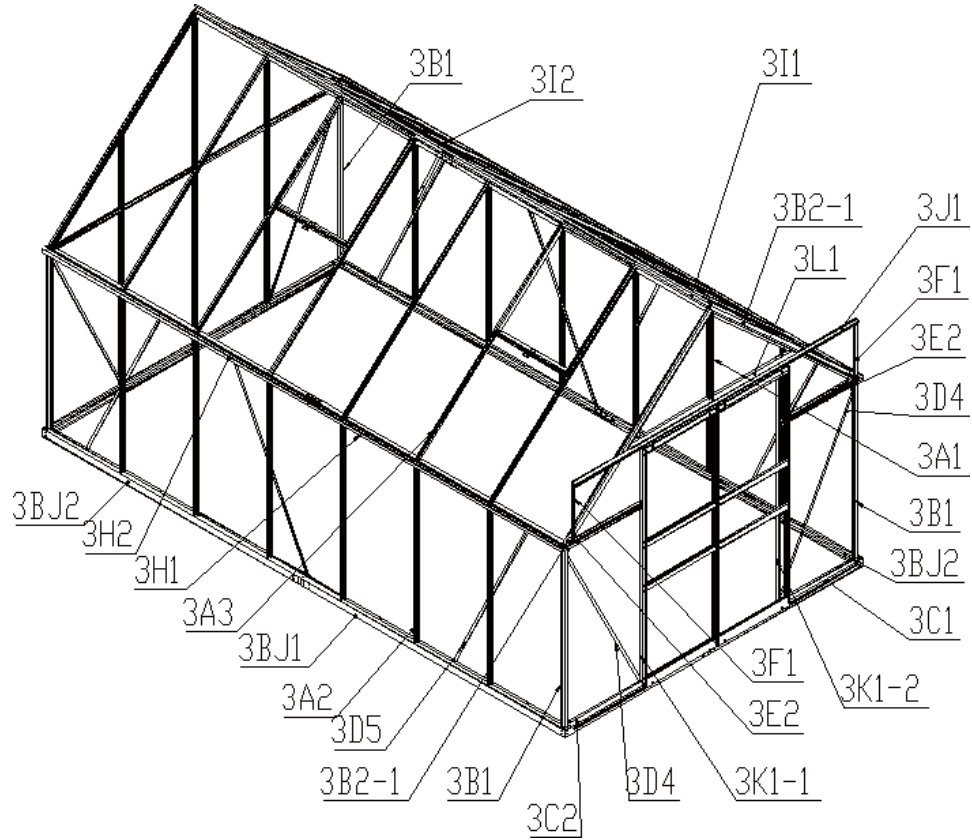

4. BAUGRUPPE DER TÜR

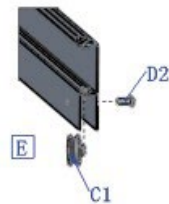
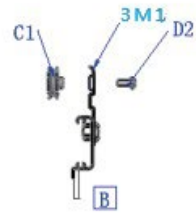
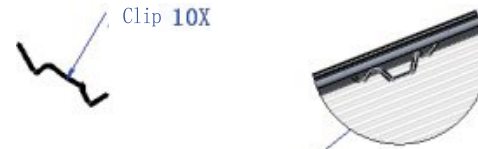
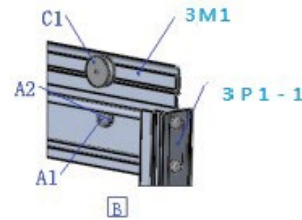
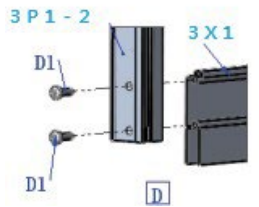
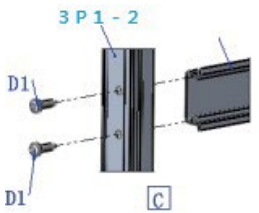
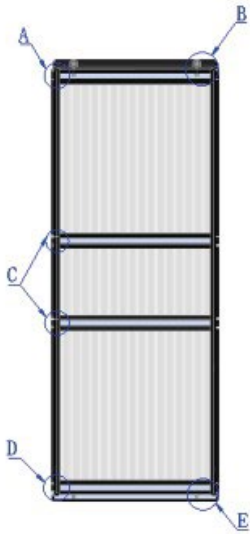
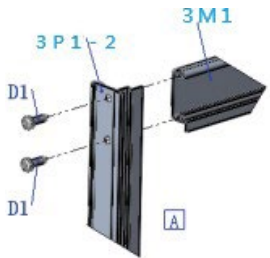

5. FENSTER-BAUGRUPPE

MODEL – MODELL

CODE – CODE

LENGTH – LÄNGE

QTY - MENGE

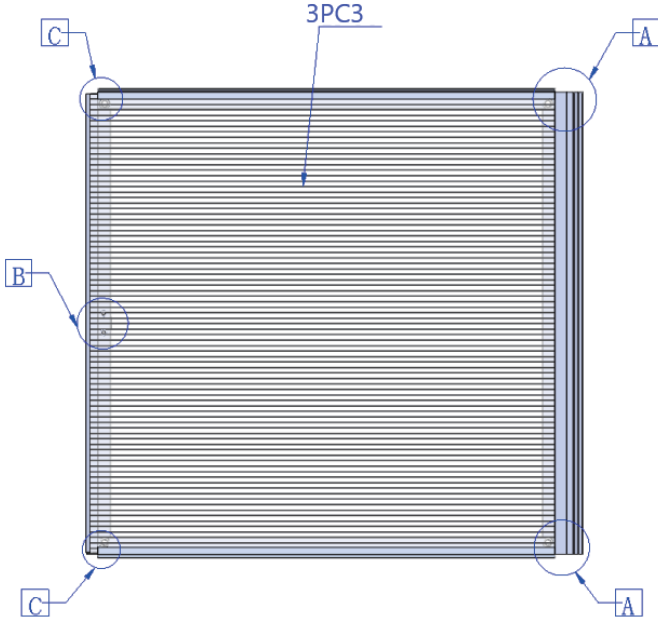
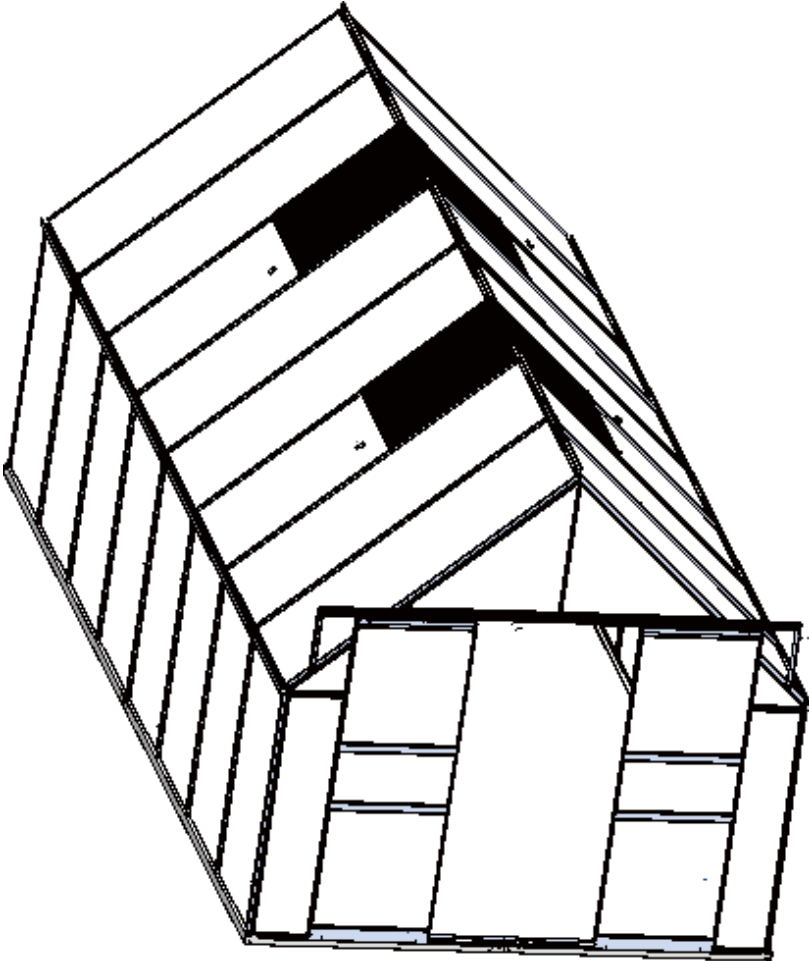

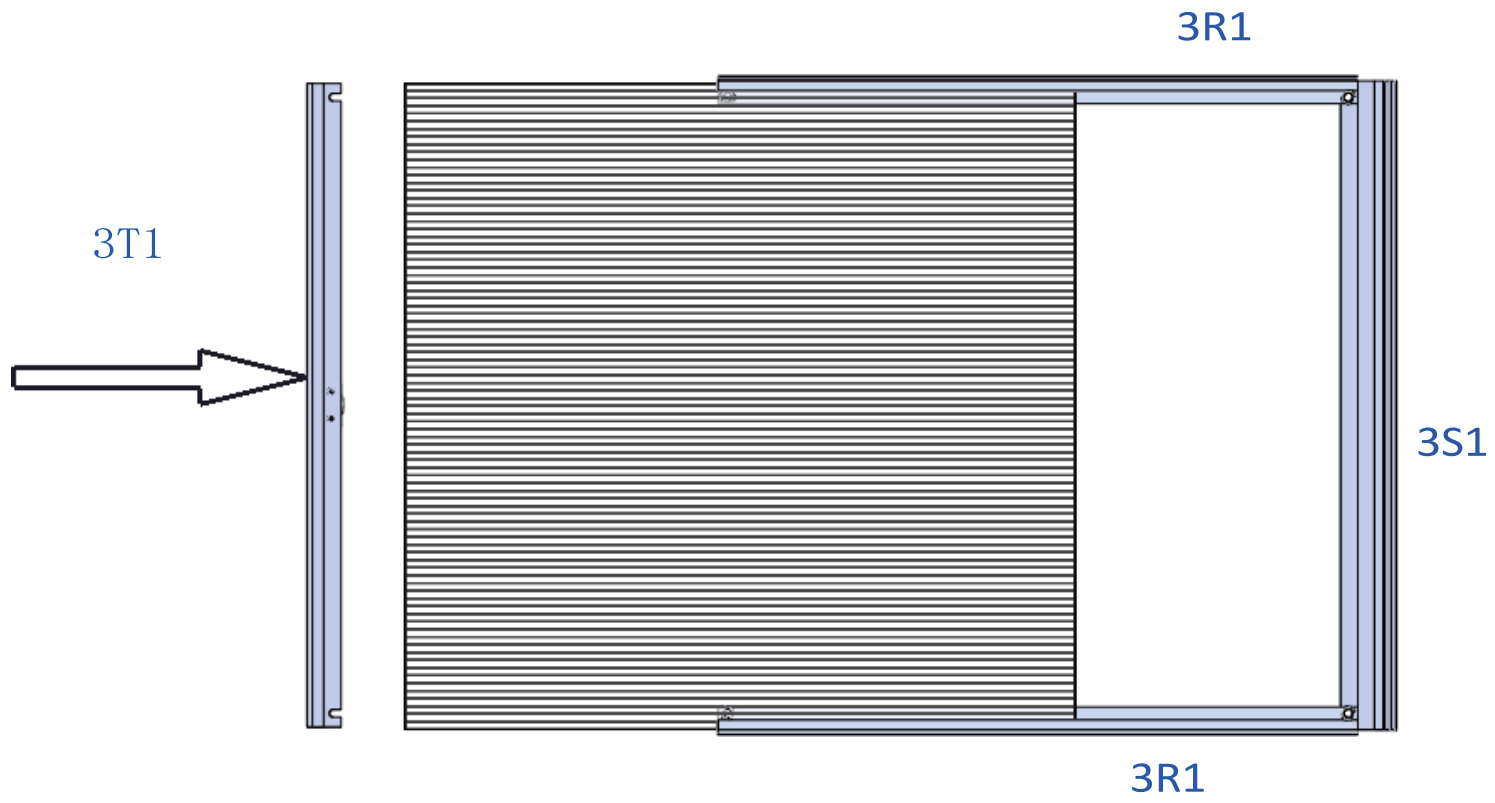
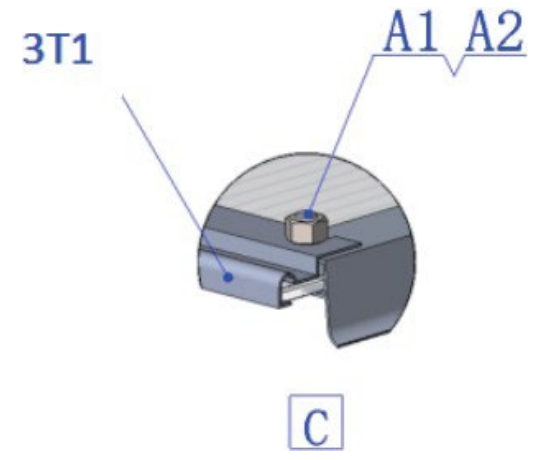
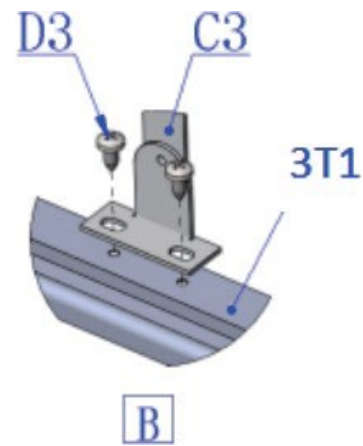
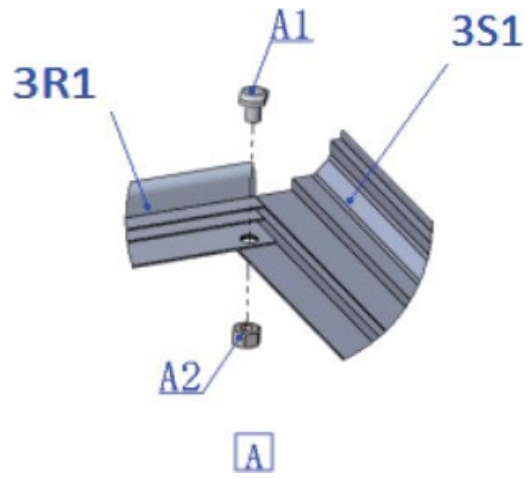

6. MONTAGE DES SOCKELS

A

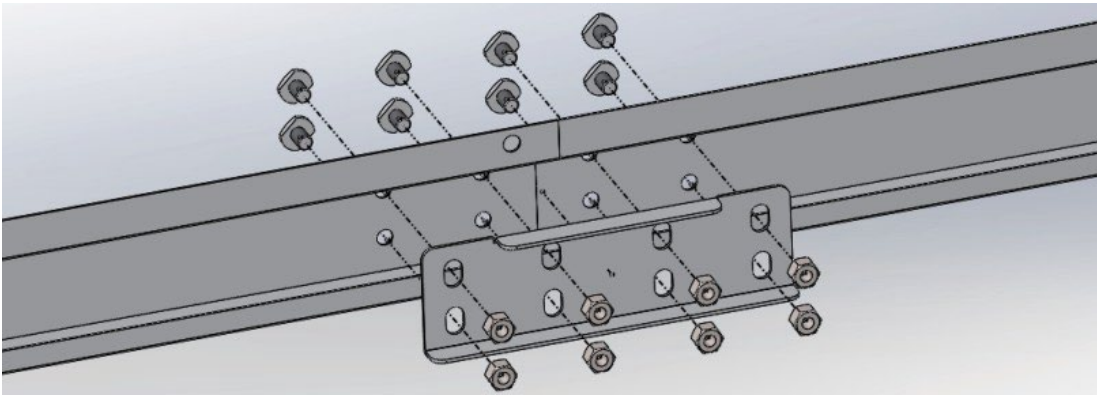
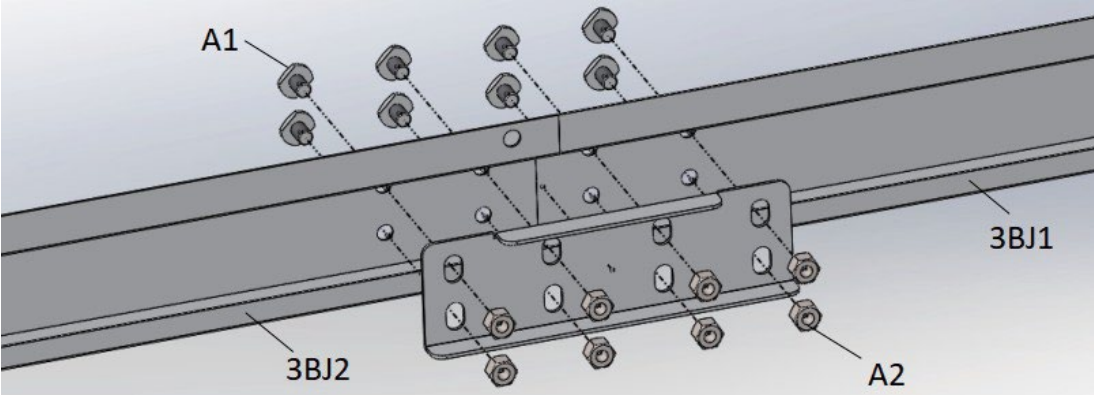

B1

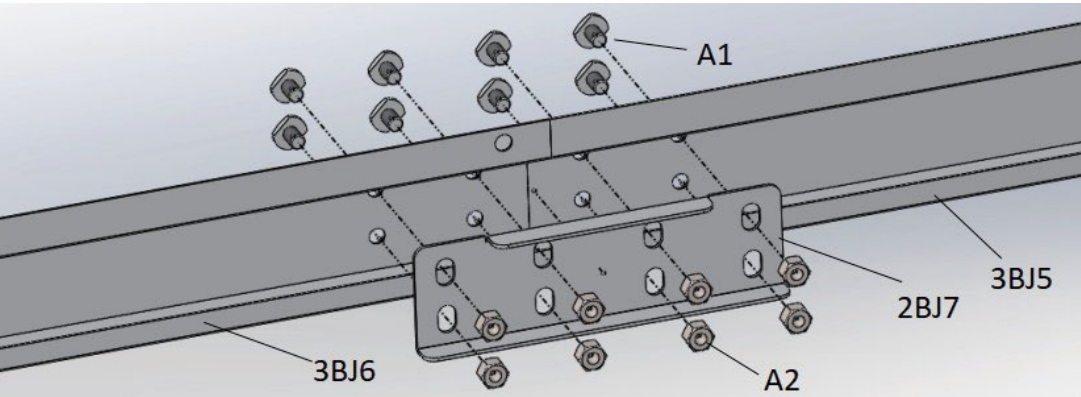

B2

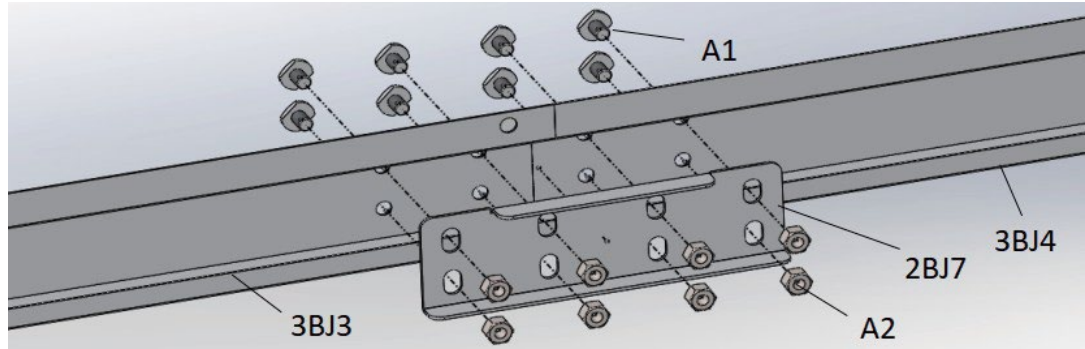

C1

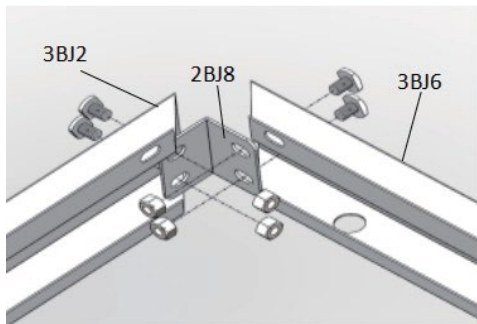

C2

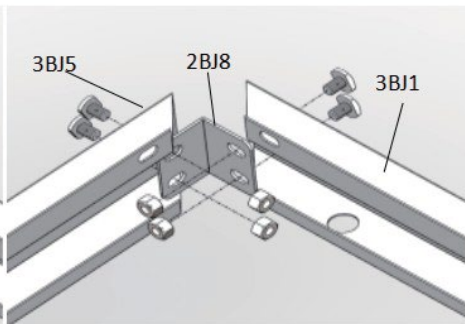

C3

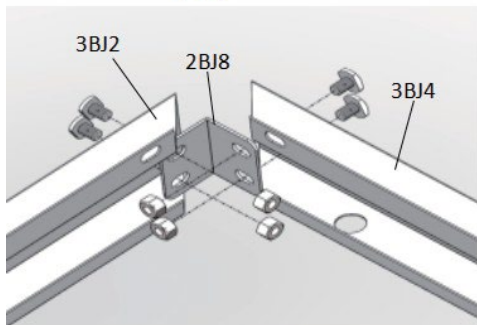

C4

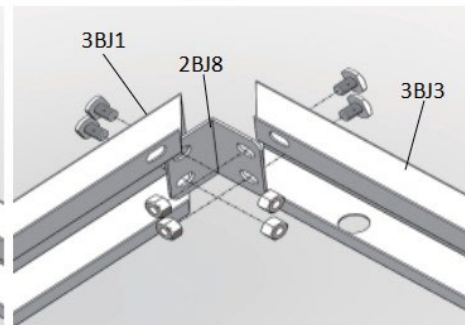

MODEL	CODE	LENGTH	QTY	MODEL	CODE	LENGTH	QTY
	3BJ1	L2099	1		2BJ7	L150*W4 4*H12	4
	3BJ2	L2059	1		A1	M6X9*3.5	32
	3BJ3	L1167	2		A2	M6-GB41	32
	3BJ4	L1207	2		3BJ6	L1207	1
	3BJ5	L1167	1				

MODEL	CODE	LENGTH	QTY	MODEL	CODE	LENGTH	QTY
	2BJ8	40	4		A1	M6X9*3.5	16
	A2	M6-GB41	16				

MODEL – MODELL

CODE – CODE

LENGTH – LÄNGE

QTY - MENGE

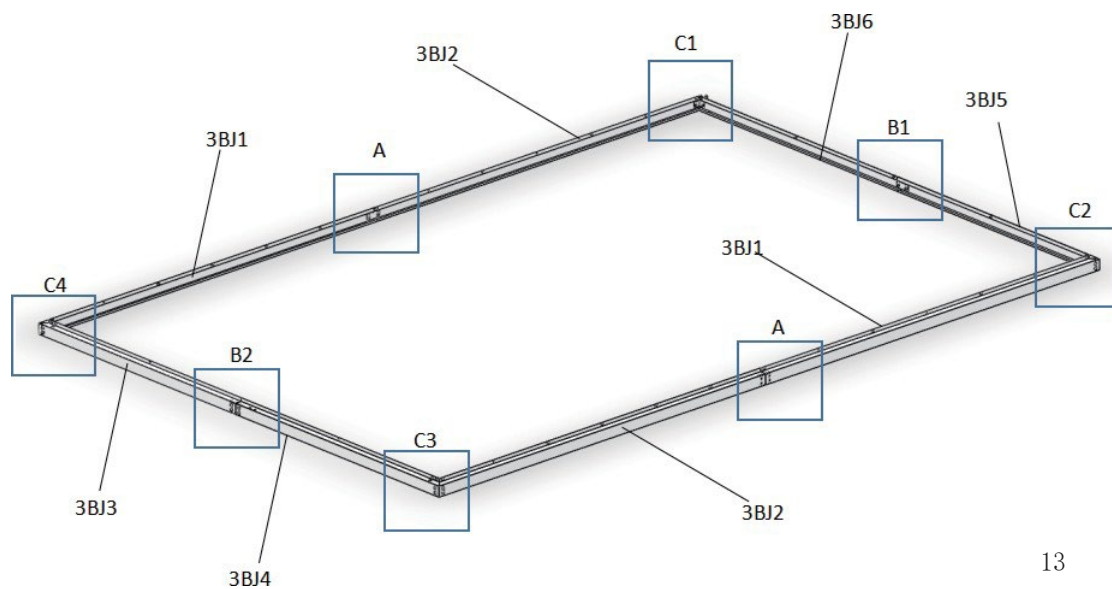





7. Montage des Grundrahmens und der Seitenkonstruktion

MODEL – MODELL

CODE – CODE

LENGTH – LÄNGE

QTY - MENGE

MODEL	CODE	LENGTH	QTY	MODEL	CODE	LENGTH	QTY
	3C1	L1060	1		3C2	L1203.6	1
	A2	M6-GB41	4		A1	M6X9	4

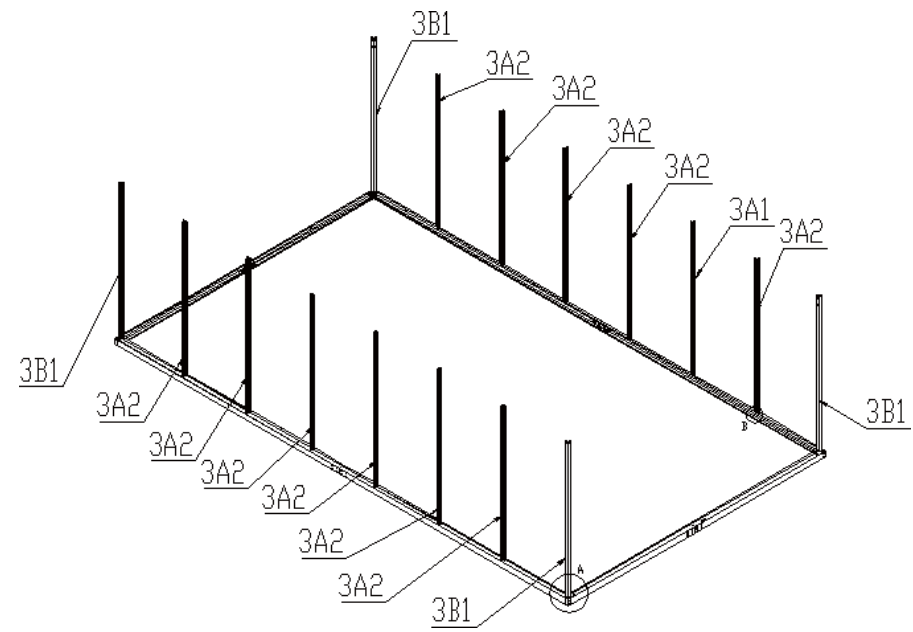
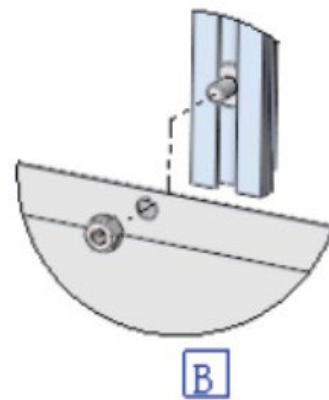
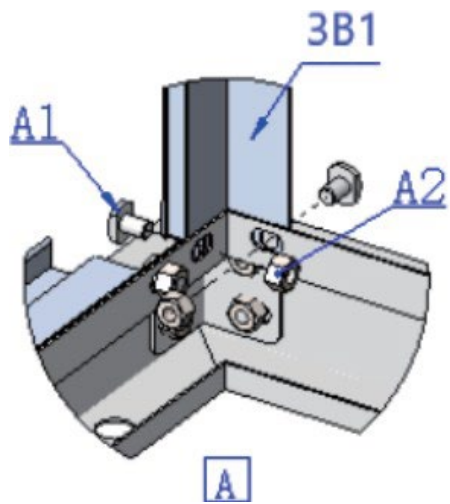
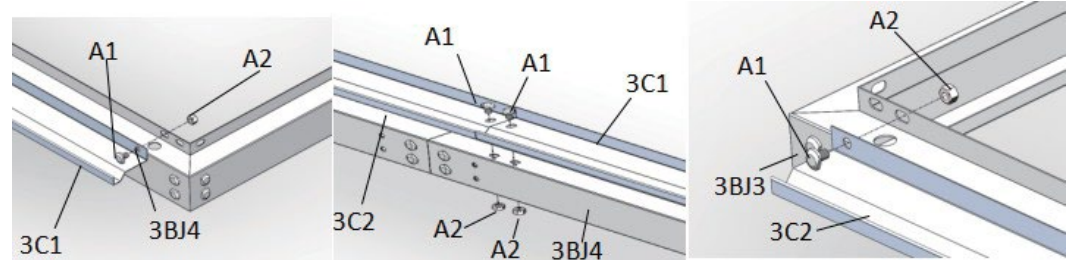
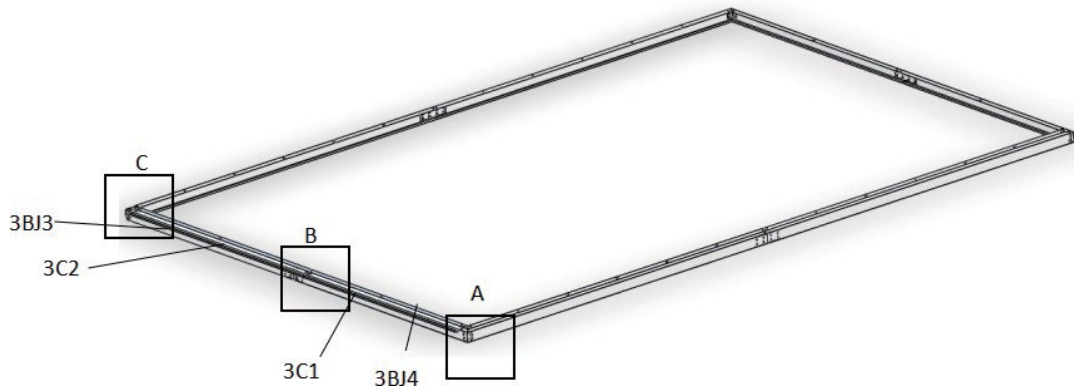





MODEL – MODELL

CODE – CODE

LENGTH – LÄNGE

QTY - MENGE

MODEL	CODE	LENGTH	QTY	MODEL	CODE	LENGTH	QTY
	3B1	1226	4		3A2	1226	12
	A2	M6-GB41	22		A1	M6X9	20

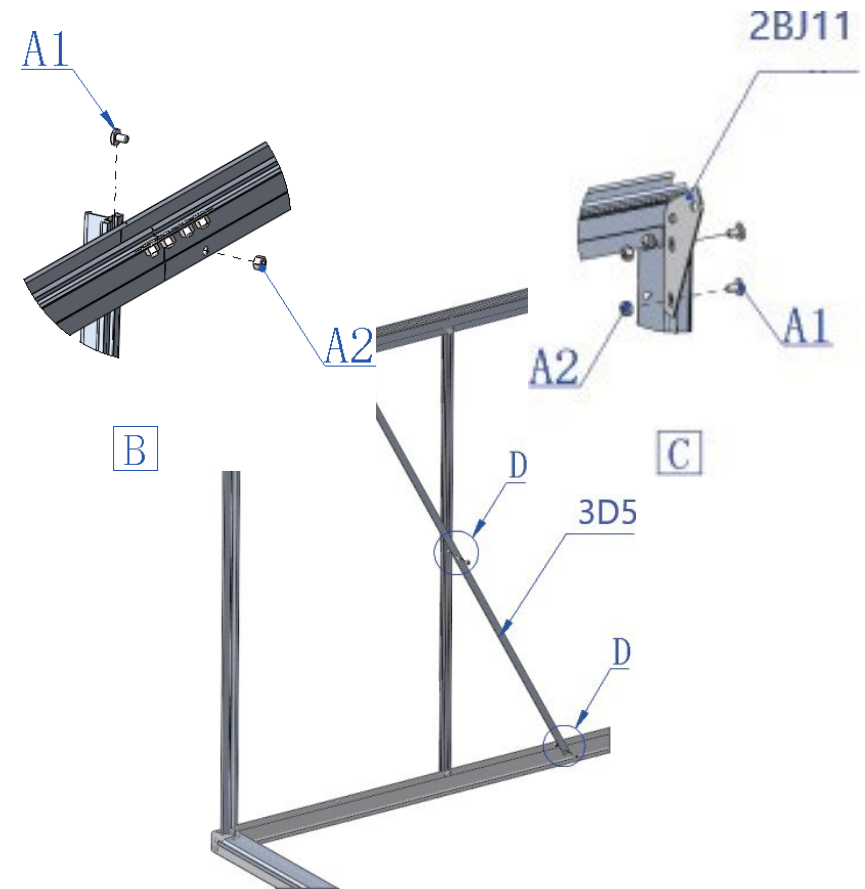
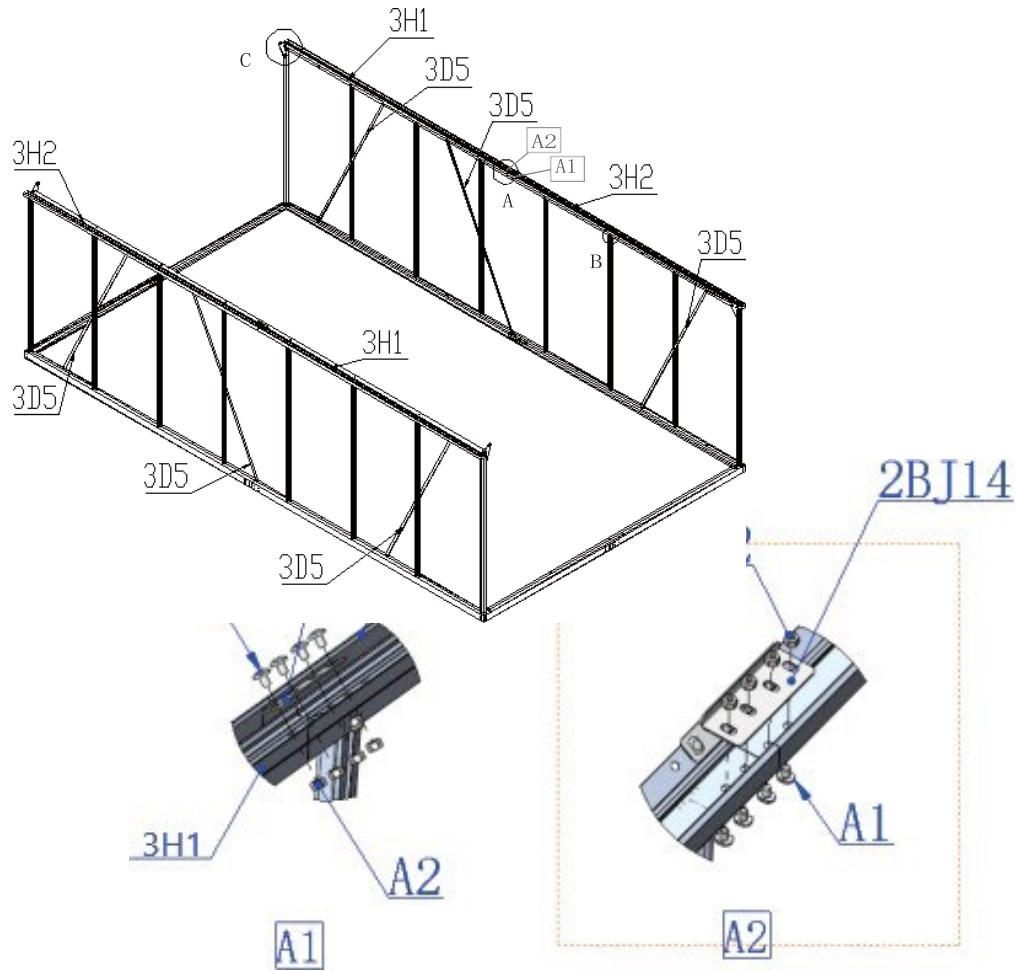









8. MONTAGE DES GEWÖLBES

MODEL – MODELL





CODE – CODE

LENGTH – LÄNGE

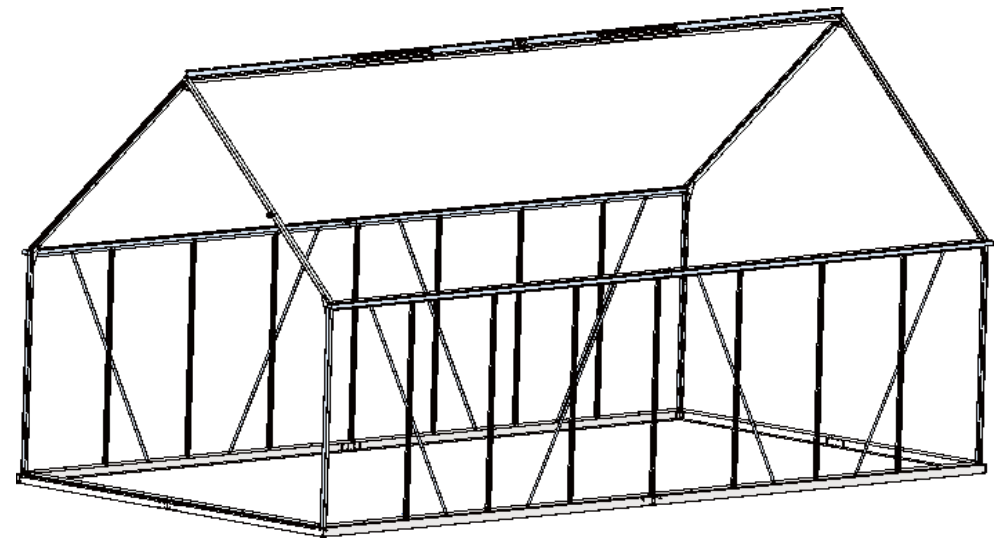
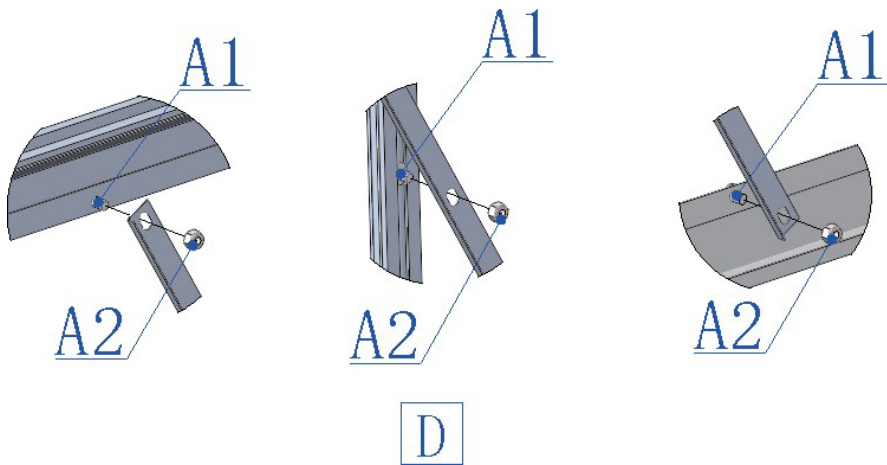
QTY - MENGE

MODEL	CODE	LENGTH	QTY	MODEL	CODE	LENGTH	QTY
	3H1	L2117	2		3H2	L2028	2
	A2	M6-GB41	54		A1	M6X9	54
	2BJ9	100	2		2BJ14	100	2
	2BJ11	144	4		3D5	L1362	8

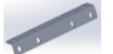

MODEL	CODE	LENGTH	QTY	MODEL	CODE	LENGTH	QTY
	311	L2083	1		312	L2010	1
	A2	M6-GB41	12		A1	M6X9	12
	2BJ9	100	1		2BJ10	175	1

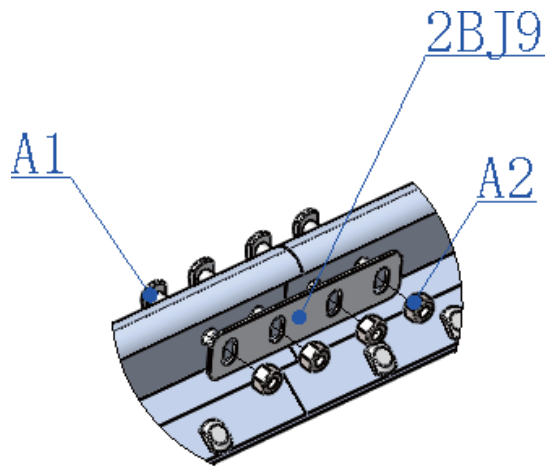

A1

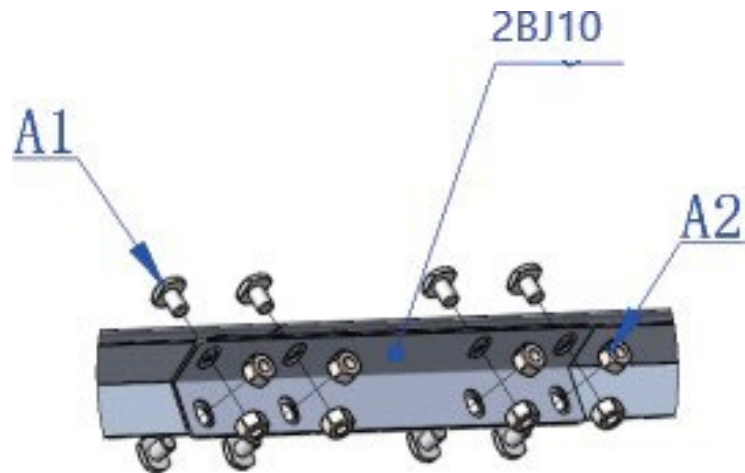

A2

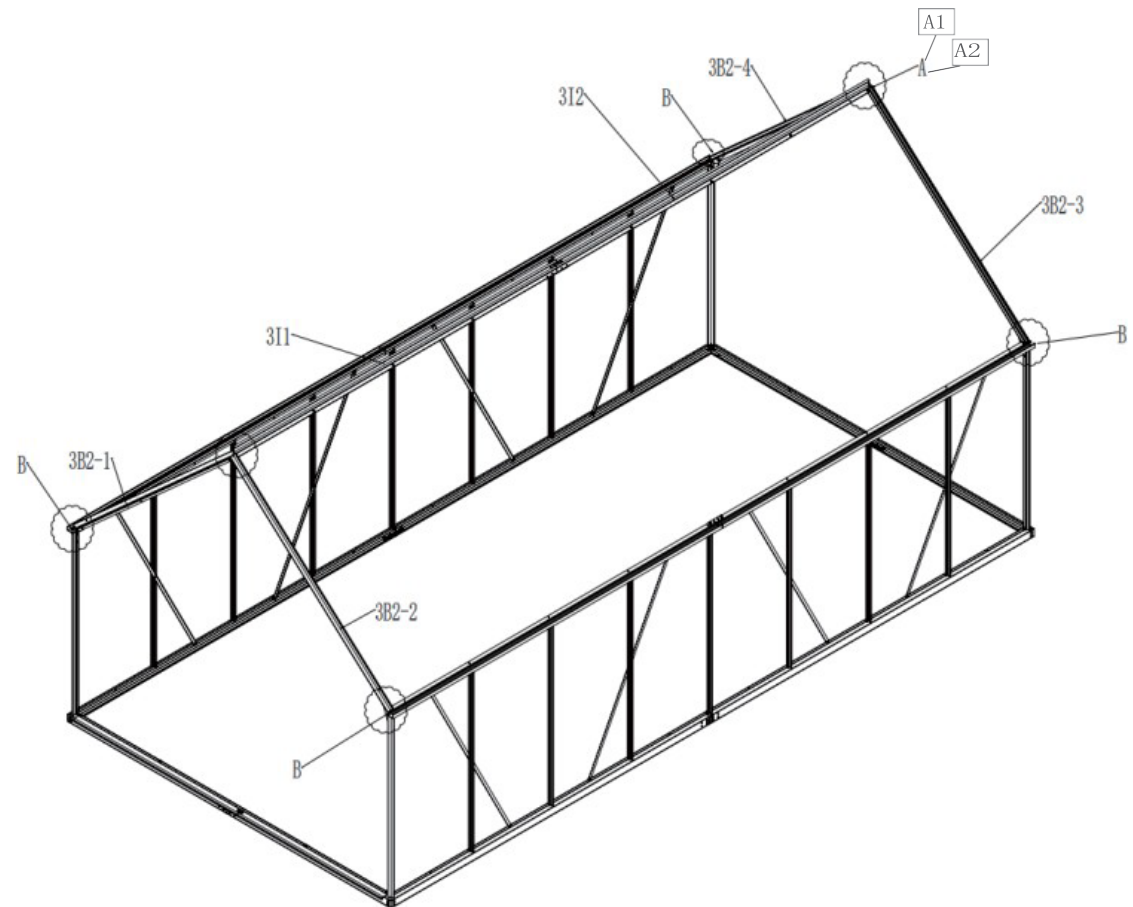







MODEL – MODELL

CODE – CODE

LENGTH – LÄNGE

QTY - MENGE

MODEL	CODE	LENGTH	QTY	MODEL	CODE	LENGTH	QTY
	3B2-1	L1575	1		3B2-2	L1575	1
	A2	M6-GB41	16		A1	M6X9	16
	3B2-3	L1575	1		3B2-4	L1575	1

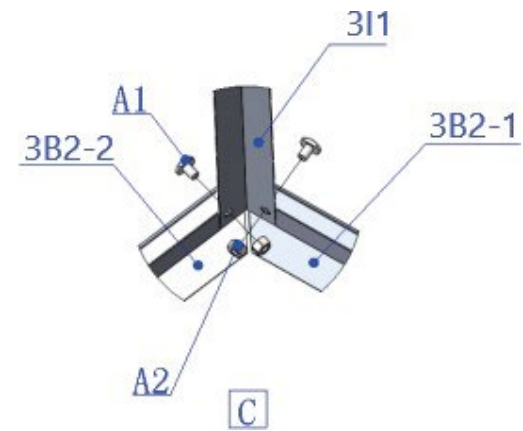
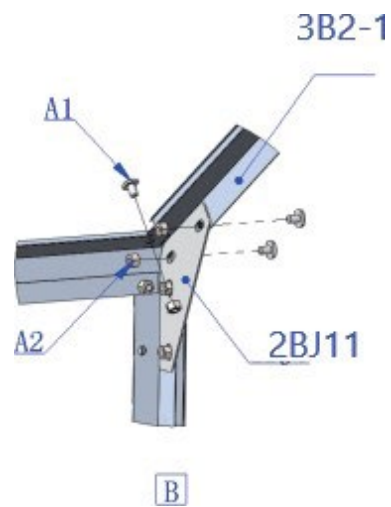
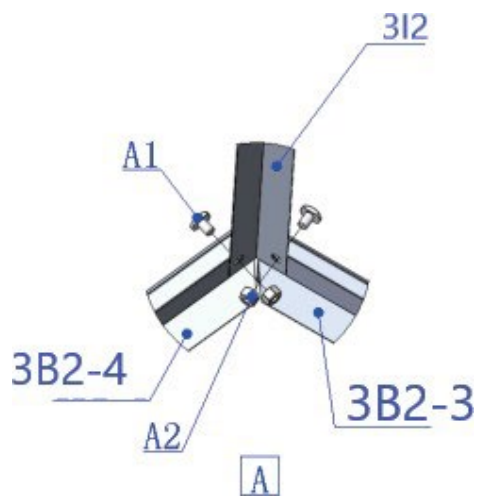

9. MONTAGE DER VORDEREN, HINTEREN UND SEITLICHEN STREBEN

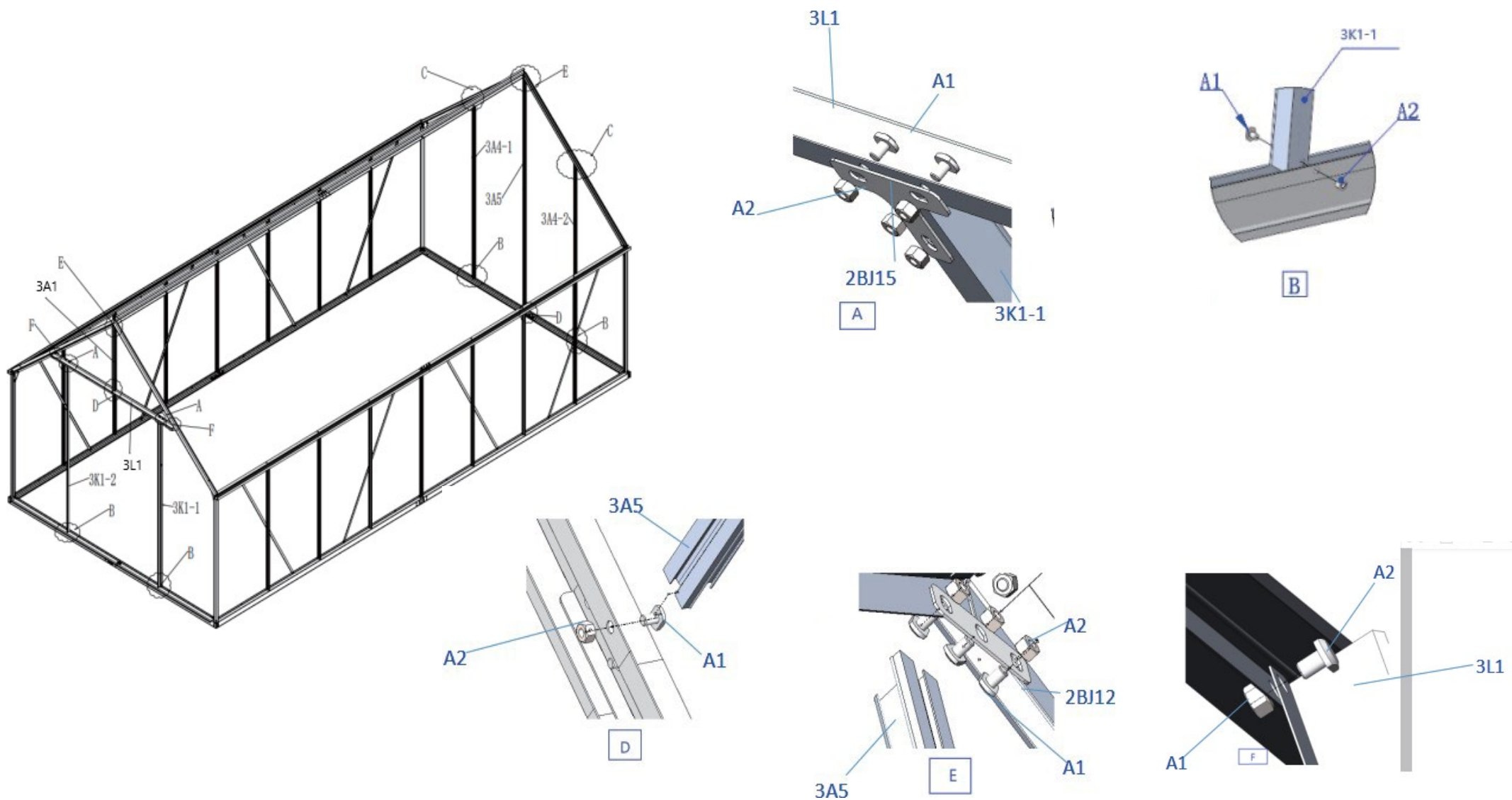

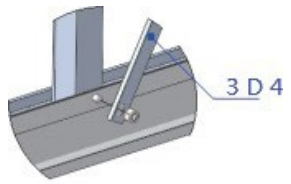

C

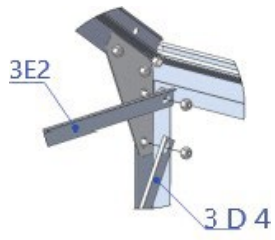

A

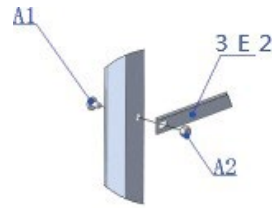

B

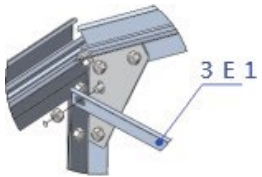

D

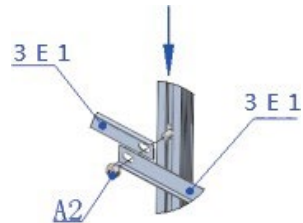

E

MODEL	CODE	LENGTH	QTY	MODEL	CODE	LENGTH	QTY
	3K1-2	L1681	1		3K1-1	L1681	1
	A2	M6-GB41	23		A1	M6X9	23
	3A4-1	L1765	1		3A4-2	L1765	1
	3A1	L581	1		3L1	L1310	1
	3A5	L2260	1				

MODEL	CODE	LENGTH	QTY	MODEL	CODE	LENGTH	QTY
	3E1	L574	4		3E2	L622	2
	A2	M6-GB41	13		A1	M6X9	13
	3E1	L1320	2				

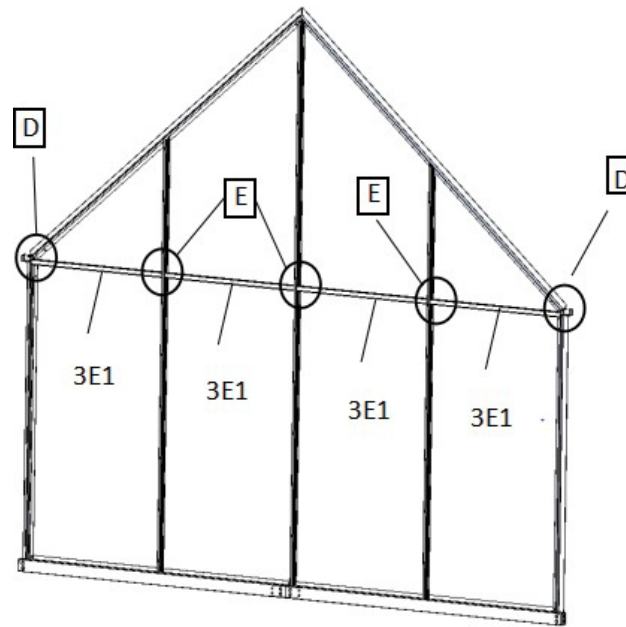
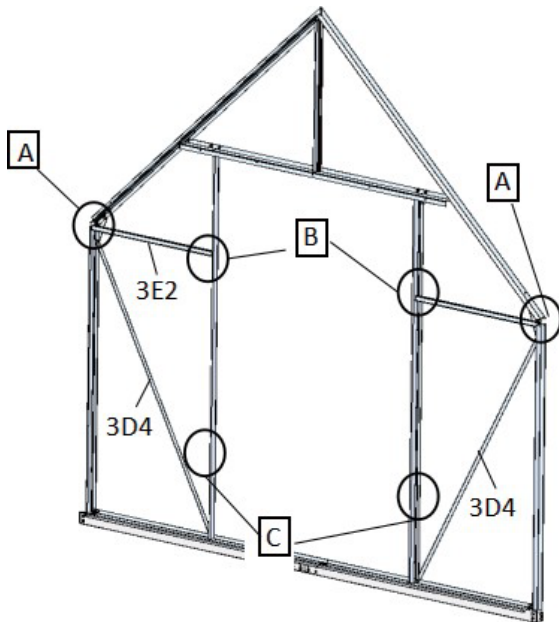

MODEL – MODELL

CODE – CODE

LENGTH – LÄNGE

QTY - MENGE

10. MONTAGE VON OBEREN VERSTÄRKUNGEN UND TÜRRAHMEN

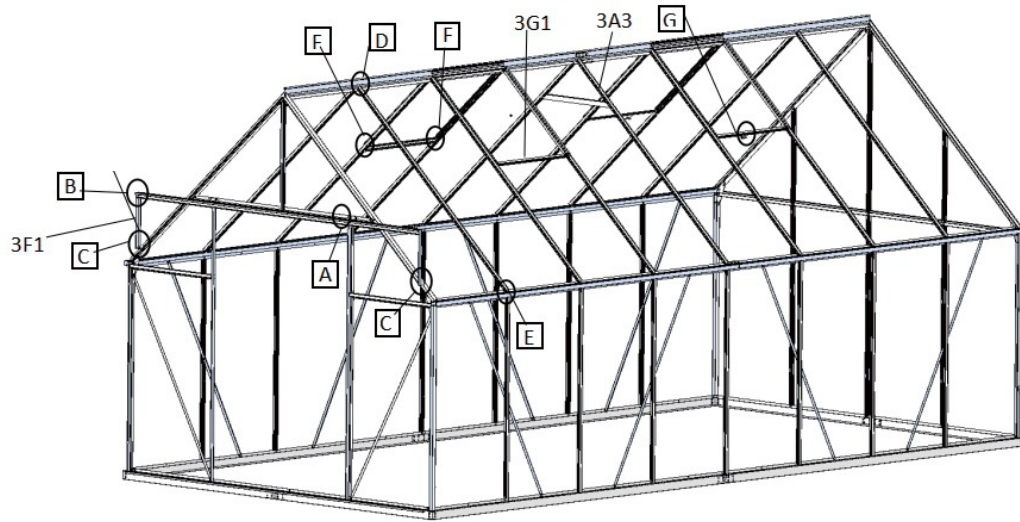

MODEL	CODE	LENGTH	QTY	MODEL	CODE	LENGTH	QTY
	3F1	L388	2		3G1	L605.5	4
	A2	M6-GB41	47		A1	M6X9	45
	3A3	L1553	12		C4	28	2
	D4	M6X40	2		C2	40	4
	D3	ST4. 2*9.5	8				

MODEL – MODELL

CODE – CODE

LENGTH – LÄNGE

QTY - MENGE

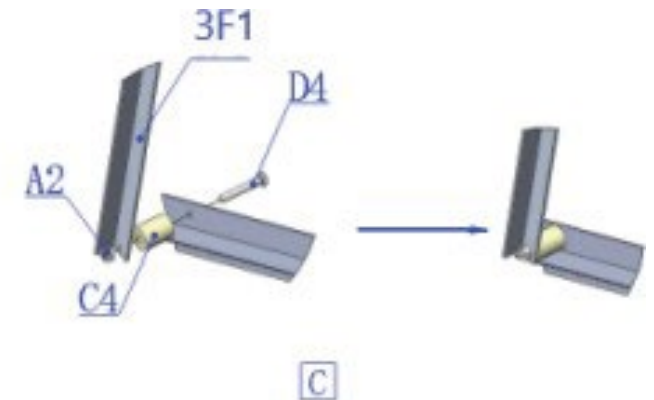
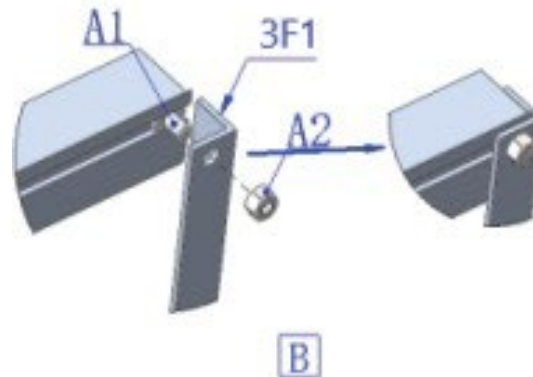
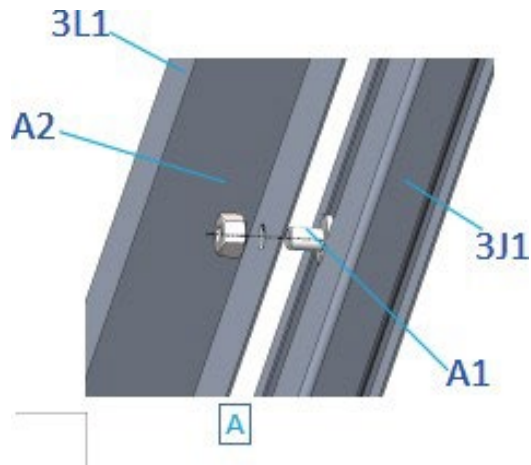

11. EINSETZEN VON SCHIEBETÜREN UND FENSTERN IN DIE KONSTRUKTION

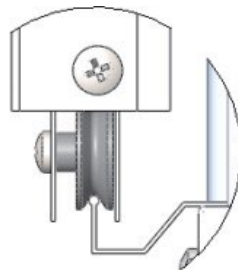
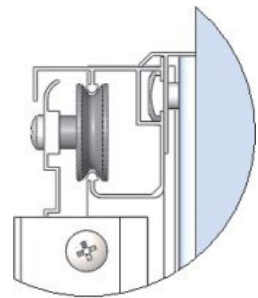
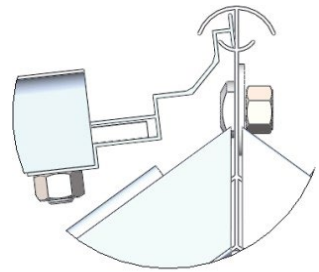
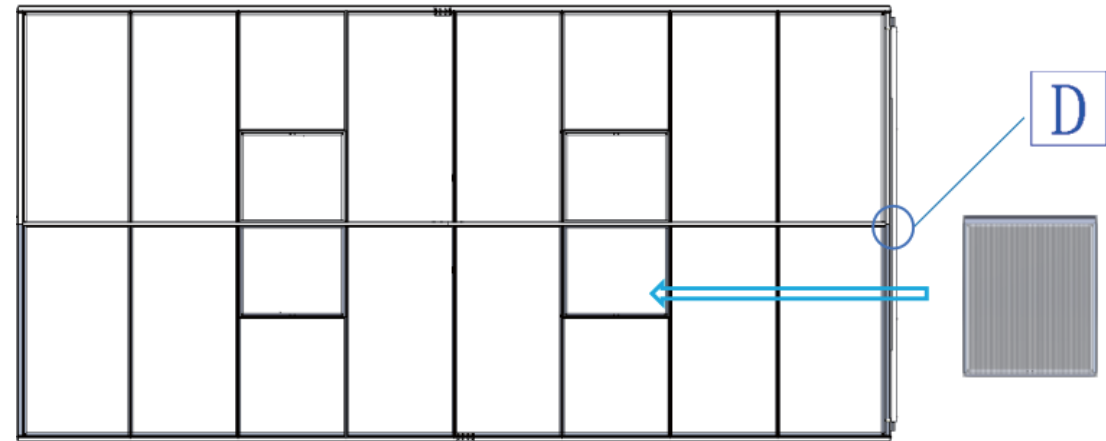
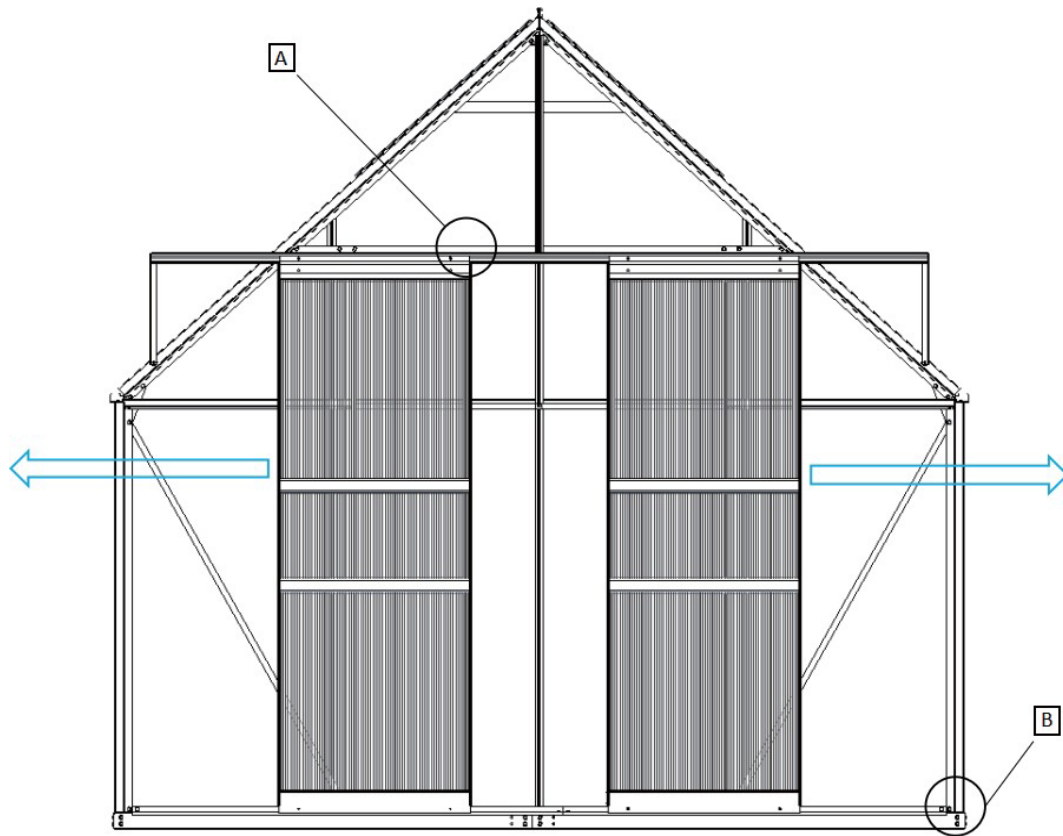

A

B

D

12. MONTAGE VON PLATTEN

MODEL – MODELL

CODE – CODE

LENGTH – LÄNGE

QTY - MENGE

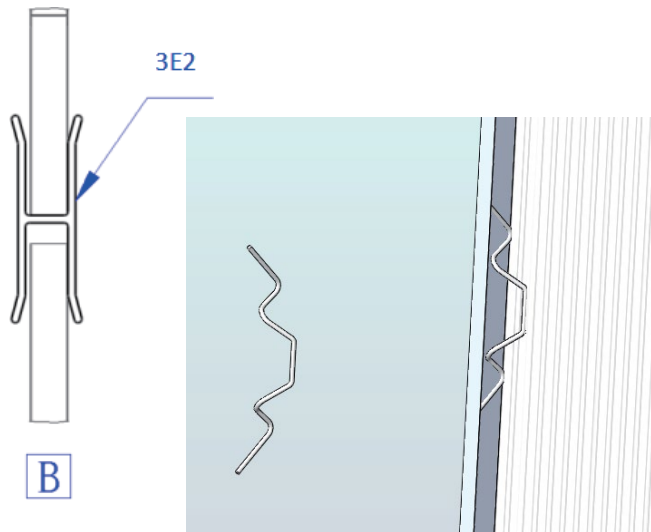
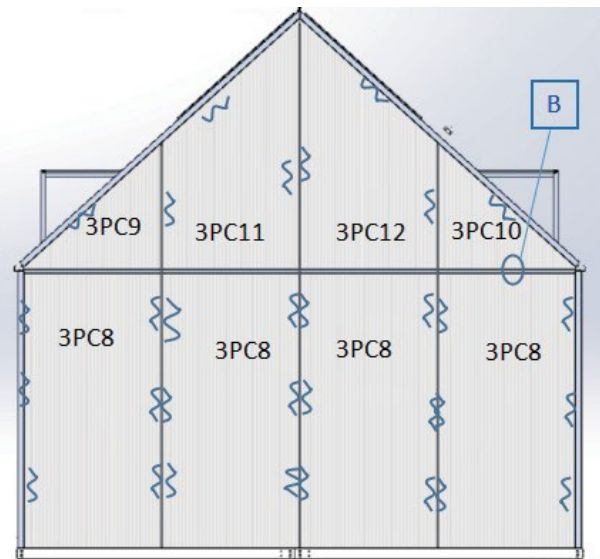
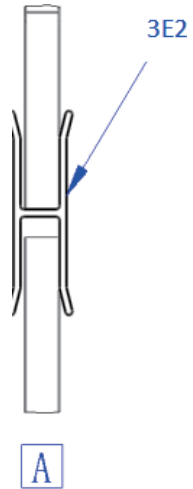
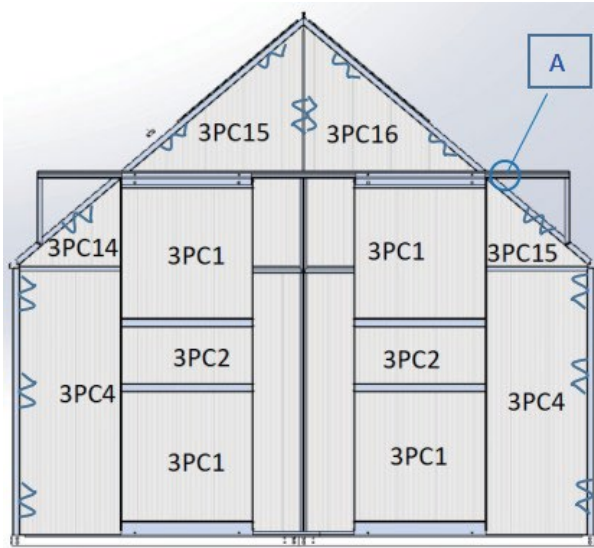

MODEL	CODE	LENGTH	QTY	MODEL	CODE	LENGTH	QTY
	3E1	L574	4		3E2	L622	2
		99	210				

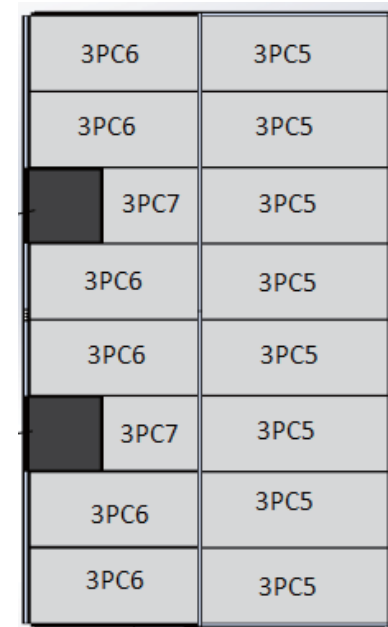
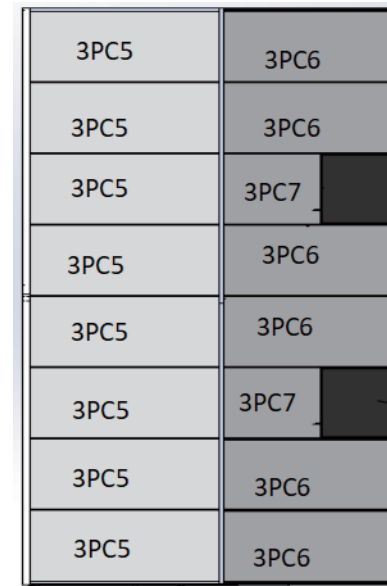

Nach der Montage

Gehen Sie regelmäßig um das Gewächshaus herum und inspizieren Sie es gründlich, um sicherzustellen, dass alle Teile richtig befestigt sind und die gesamte Konstruktion in Ordnung ist. Überprüfen Sie alle Schrauben und Muttern sowie alle Verbindungen, um sicherzustellen, dass sie sich in der richtigen Position befinden.

Wir empfehlen Ihnen dringend, den gefallenen Schnee sofort zu entfernen. Lassen Sie keinen Schnee über Nacht auf dem Dach liegen. Halten Sie immer einen Freiraum von ca. 1 Meter Breite auf allen Seiten.

Achten Sie darauf, dass sich kein Schnee an den Seiten des Gewächshauses ansammelt. Andernfalls würde der Druck von den Seiten nach innen drücken und das Gewächshaus könnte einstürzen.