

Ax2

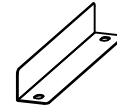

Bx4



Cx2



Dx8



Ex8



Fx4



Gx8



Hx1

①

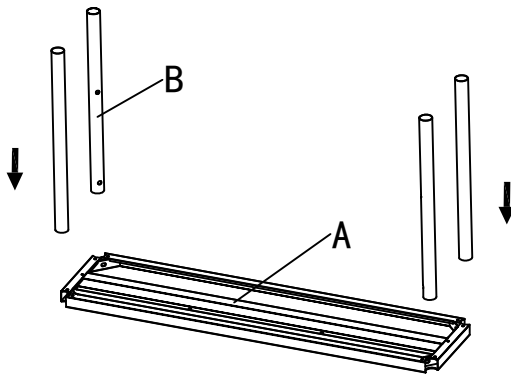

②

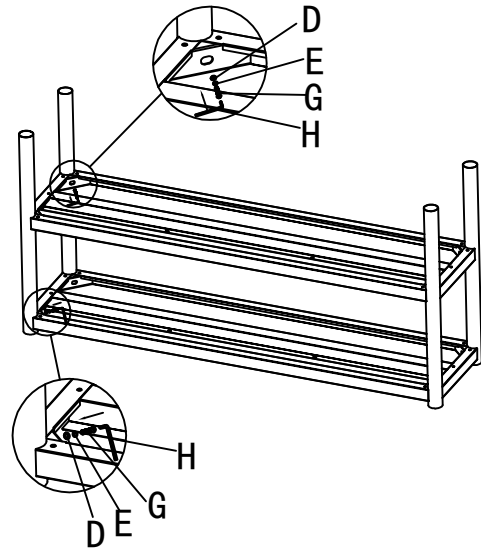

③

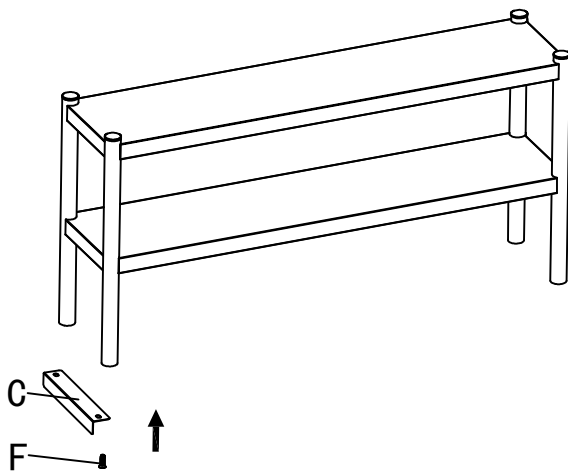

④

